

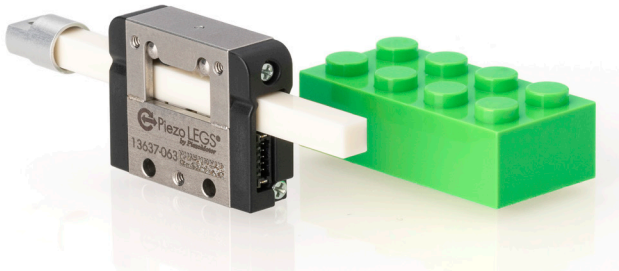

Acuvi LEGS® LL06 Piezo Linear Actuator



Key features

- Integrated encoder and guiding
- >6.5 N force
- Sub nanometer precision
- Direct drive and no backlash
- No power draw in hold position
- Unparalleled size to force ratio

Product Description

The LL06 is an exceptionally compact direct drive piezo linear actuator. It can generate a push-pull force of up to 6.5 Newtons with a weight of only 16 grams, resulting in an impressive size-to-force ratio.

With no backlash, a holding force of over 6.5N, and the capability to micro-step in the sub-nanometer range, makes it ideal for

high-precision applications. It is available with or without an integrated encoder and an option for drive rod guiding.

The selectable drive rod lengths enable adaptability to diverse application scenarios. The motor's seamless integration will likely simplify and minimize the overall system size.

Product Dimensions

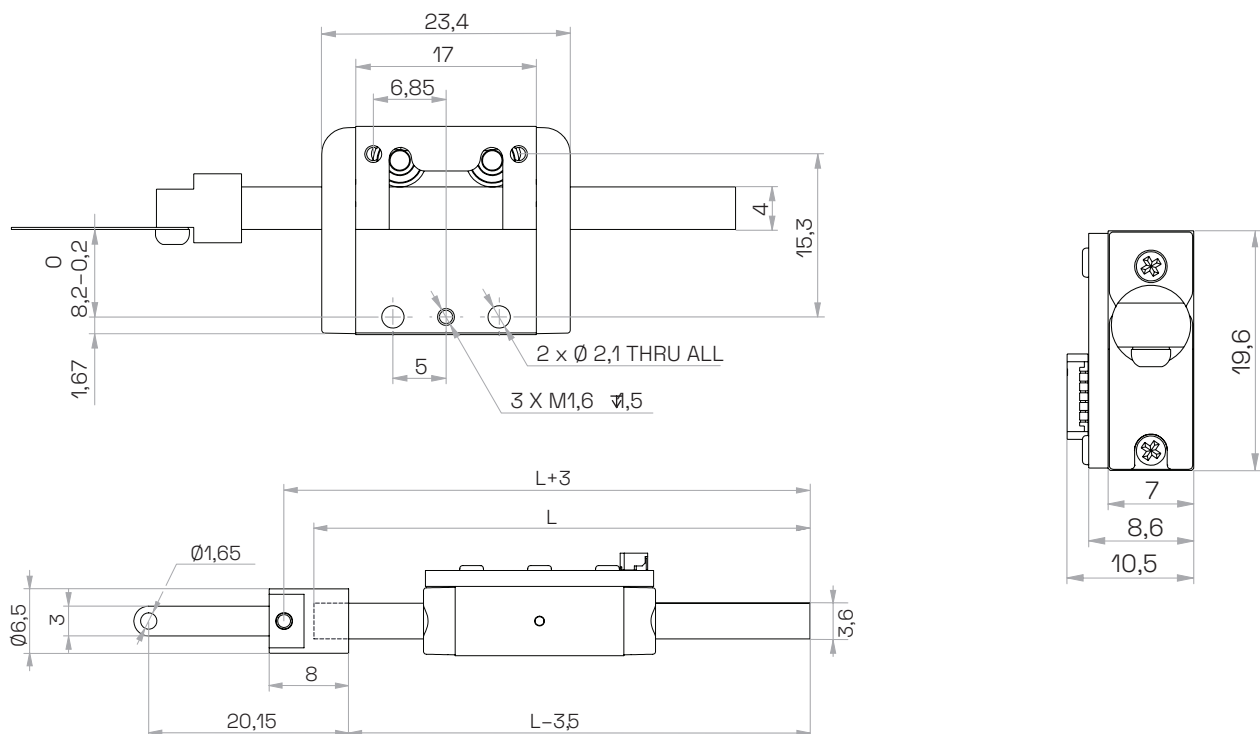

Acuvi LEGS® Linear LL06 specifications

TYPE	STANDARD
Maximum stroke	74.1 mm
Maximum speed (driver dependent)	24 mm/s
Minimum speed (driver dependent)	1 nm/s
Max operating frequency	3 kHz
Minimal incremental	0.5 nm
Stall force	6.5 N
Holding force	>6.5 N
Vacuum	No
Non-magnetic	No
Operating voltage	42-48 V
Power consumption	5 mW/Hz
Mechanical size L x H x D with guides and encoder	23.4 x 19.6 x 10.5 mm
Mechanical size L x H x D without guides and encoder	17 x 19.6 x 10.5
Weight with 50 mm drive rod	16 g
Material in motor housing	Stainless steel
Operating temperature (recommended)	-20 to +70°C
Storage temperature	-50 to 85°C
Built in encoder	Yes optional
Encoder resolution	1.25 µm (encoder E1)
	0.08 µm (encoder E2)

All specifications are subject to change without notice. Latest data sheets are available for download at acuvi.com

Controllers

PMD301 1-axis micro-step driver/controller - max 3 kHz, RS485 or USB
 PMD401 1-axis micro-step driver/controller - stackable PCB, max 1.5 kHz, RS485 or SPI

Accessories

Starter Kit PMD401 controller, motor cables, USB-to-RS485 cable, and power supply
 Piezo Drive lab software downloadable from acuvi.com

